



EU DECLARATION OF CONFORMITY
DECLARACIÓN UE DE CONFORMIDAD

3EBasor

CABLE TRAY SPECIALIST

www.basor.com



Certificado Nº SGI 3198065/11



Certificado Nº SGI 3198065/12

The company / *La Empresa:*

BASOR ELECTRIC, S.A.

Address / *Dirección:*

Av. Alcodar, 45-47, 46700. Gandía (VLC), Spain.

Declares that the product:

Declara que el producto:

BASORCANAL WT

Installed in accordance to the installation standards, manufacturer's instructions and professional rules, duly maintained and used for the applications as intended.

Instalado de acuerdo con las normas de instalación, instrucciones del fabricante y conforme a las reglas profesionales, debidamente mantenido y utilizado en las aplicaciones para las que está previsto.

Complies with the essential requirements of the Council Directives:

Cumple con los requisitos esenciales de las Directivas del Consejo:

2014/35/UE (Low Voltage Directive) / (Directiva de Baja Tensión)

Incorporated in the Spanish Legislation in: R.D. 187/2016.

Incorporado en la Legislación Española en: R.D. 187/2016.

And it is suitable and safe for the intended use and it is in conformity with the following standard:

Es adecuado y seguro para el uso a que está destinado y es conforme con la siguiente norma:

UNE EN 50085-1

UNE EN 50085-2-1

UNE EN 50085-2-2

Additional information:

Información adicional:

This product is intended to be installed and maintained by skilled persons, it may be used by ordinary persons only as a replacement part, to substitute for an identical device.

Este producto está previsto para ser instalado y mantenido por un profesional, puede ser usado por una persona no formada para reemplazamiento de uno idéntico.

Place and date:

Lugar y fecha:

Gandía May 2016

Gandía Mayo 2016

Technical department / *Departamento Técnico*

UNE-EN 50085
 REV.20/04/2016

WT

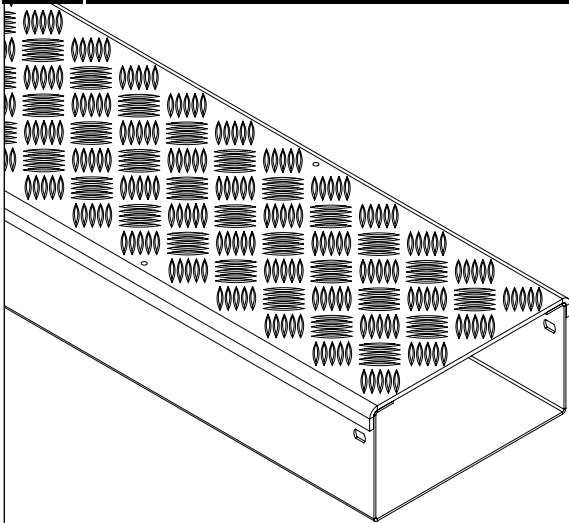

Models (BxH):

100X100; 200X100; 300X100; 400X100; 500X100; 600X100.

Finishes: PG, Aluminium (AL 5754).

Characteristics of the cable tray:

- Metallic.
- Impact strength: 20J.
- Minimum temperature of -45°C .
- Maximum temperature of 120°C .
- Non-flame propagating component.
- System with electrical continuity.
- Without electrical isolation.
- With access cover that can only be opened using tools.
- Maximum permissible point load of 150 Kg.
- Degree of protection: IP2X

ASSEMBLING INSTRUCTIONS

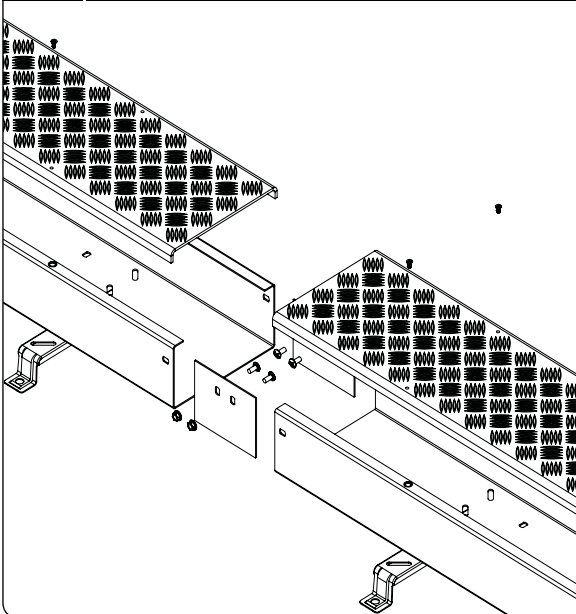

- All accessories have a pre-assembled joint.
- Each trunking must be mounted on 3 SV supports and these ones must be anchored to a rigid surface. The accessories only need 1 SV support. Every SV support needs 2 B1 Set to be assembled with the trunking body.
- To joint the pieces among themselves B1 Sets (REF 2/4356) are needed.
- Covers are fixed using DIN7991 screws M6x16 (REF 2/10265). The nuts are delivered already riveted with the trunking body.
- There are fast assembly nuts TMK (REF 2/10266), for cutting work situations. The trunking has some holes prepared to facilitate the mounting.
- To ensure maximum permissible point load of 150 Kg in 400 wide trunking or higher, a separator profile (REF 2/10180) must be installed.
- Tray installation for electrical systems should NOT run under other types of canalizations such as water, vapour or gas canalizations.
- To guarantee a good ventilation, we recommend installing the trays keeping a minimum distance of 250 mm between each tray.
- Trays placed on supports shall have to keep a gap of 20 mm from the wall to allow the correct ventilation of the cables.

Accessories:

 This family has a large array of accessories: Horizontal bend 90° , horizontal bend 45° , vertical inside and outside bend, TE derivation, union joint, reduction 100 mm, blind end, divider profile and covers for the trunking made of PG steel or anti slipping aluminium.